

minimum clearance 10'-6" to 14'-0"

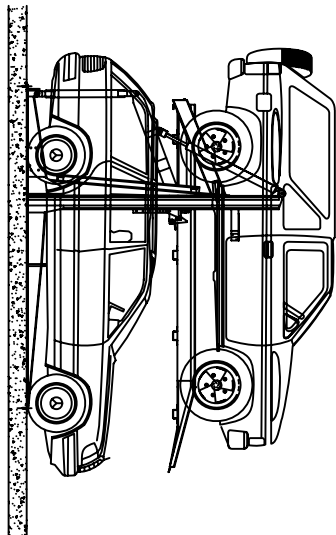

ALL UNITS AVAILABLE AS SINGLE STANDING OR SHARED WITH COMMON LEG

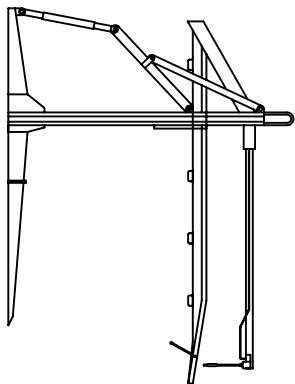
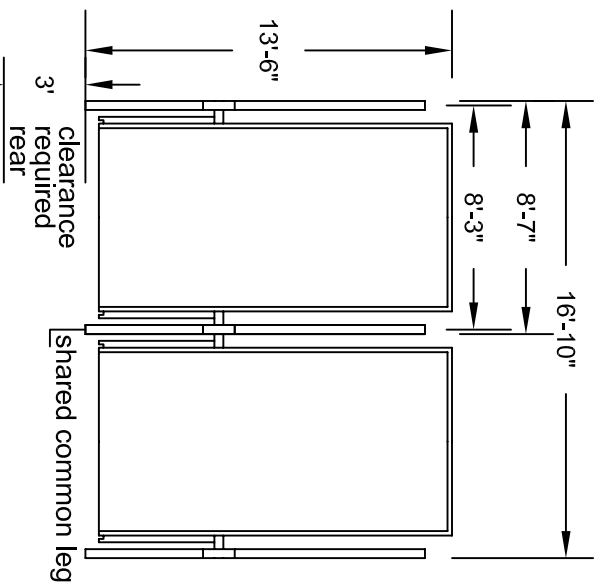
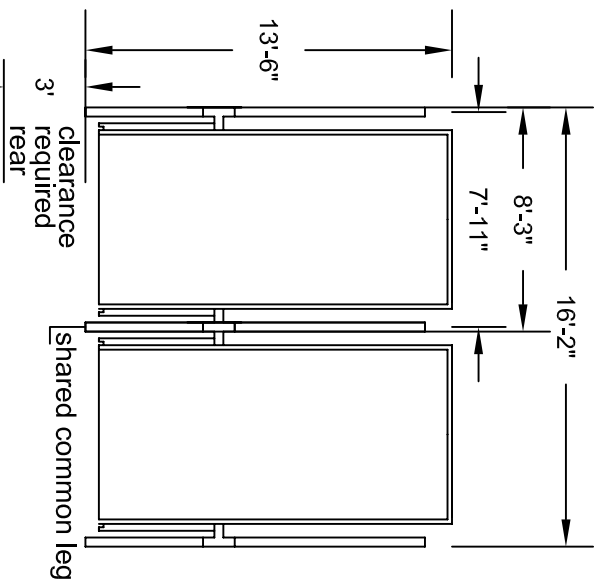
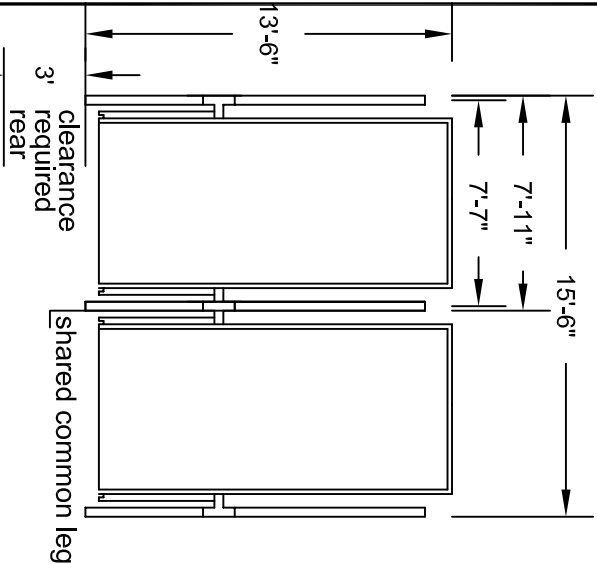

THIS CONFIDENTIAL DOCUMENT IS THE PROPERTY OF PARK PLUS, INC. AND SHALL NOT BE GIVEN, COPIED OR REPRODUCED WITHOUT PRIOR WRITTEN CONSENT.

PARKING SYSTEMS

PARK PLUS Inc.™

DP003 L-11
SCHEMATIC PLAN

DP003 L-12
SCHEMATIC PLAN

DP003 L-13
SCHEMATIC PLAN

DATE: _____
DRAWN BY: _____
CHECKED BY: _____
PROJECT DRAWING

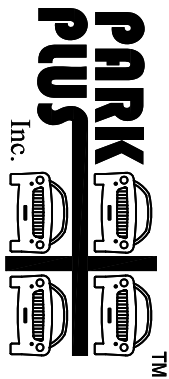

480 MAIN AVENUE UNIT 1
WALLINGTON, NJ 07057
TEL: (973) 574-8020
FAX: (973) 574-8030
www.parkplusinc.com
email: info@parkplusinc.com

PROJECT **DOUBLE PARKING SYSTEMS**
TECHNICAL SPECIFICATION

DRAWING DESCRIPTION

DP003 TYPES L11 L12 L13

DRAWING NOT TO SCALE

REVISIONS:
△